

# JIB CRANE 360



## DESIGN FEATURES

---

500 KG WORKING LOAD LIMIT

---

MOTORIZED CHAIN HOIST

---

2 SPEED HOIST MOTOR

---

EASY TO OPERATE

---

**Farnese Australia** was founded in 2000 by the Farnese family, whose members have decades of combined professional experience and expertise in both the global stone industry and the local stone machinery manufacturing industry. We are the only designer and manufacturer of stone fabrication machinery in Australia and our machines have found homes throughout Australia, New Zealand, the United States, the United Kingdom, and Vietnam.

With over 20 years of experience in the stone industry, the team at Farnese have the experience it takes to design, install and maintain the equipment needed in your industry.

The JIB CRANE 360 is one of the most important elements in any workshop. It is designed to be bolted directly to the ground thanks to a large base plate. This base plate is anchored to the ground by bolts which are chemically set to a levelled concrete floor which must be at least 150mm in thickness.

The JIB CRANE 360 is fitted with a motorized chain hoist; the two speed motor enables the operator to manoeuvre the hoist with ease and accuracy in an up down motion.



# JIB CRANE 360

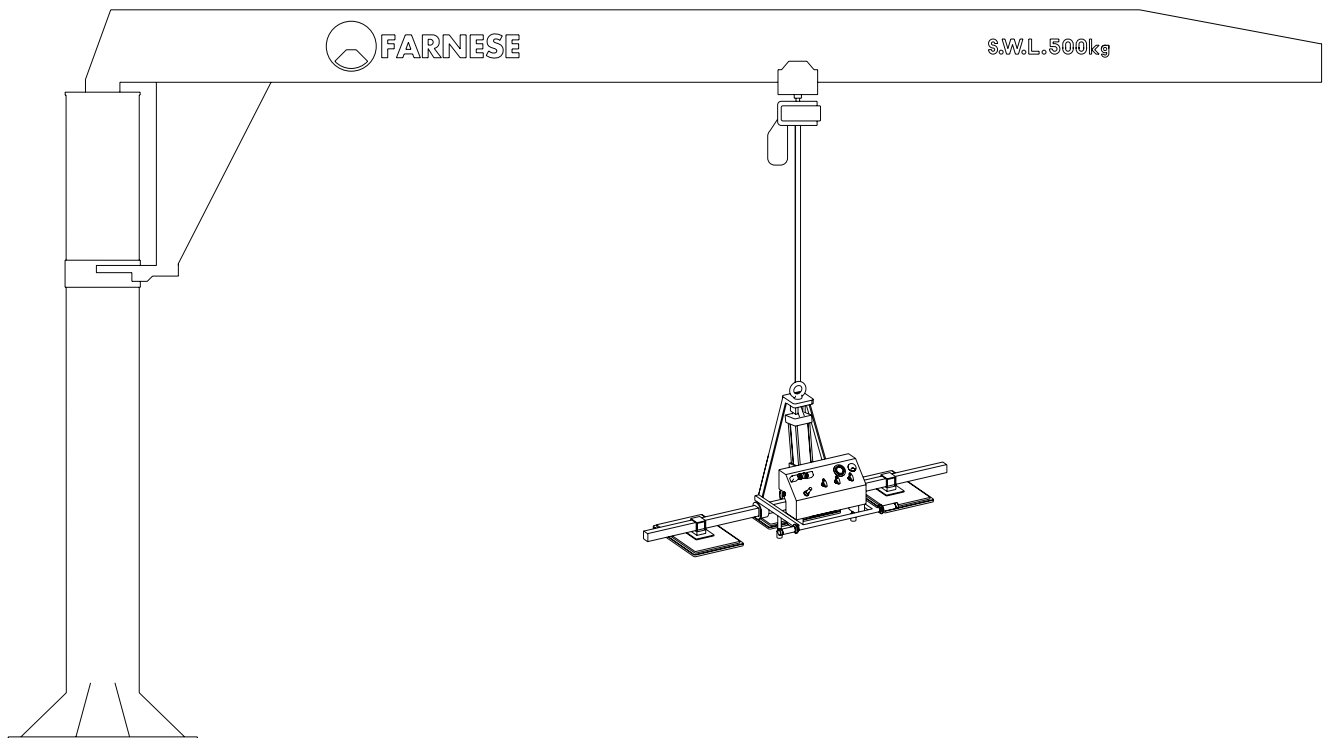

## TECHNICAL SPECIFICATIONS

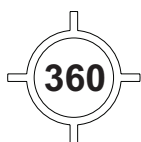

### DIMENSIONS OF INSTALLED MACHINE

STANDARD*	METRIC	IMPERIAL
LENGTH	7300 mm	287.4 in
WIDTH	1100 mm	43.3 in
HEIGHT	4000 mm	157.5 in
WEIGHT	900 kg	1980 lb
LOAD (WORKING LOAD LIMIT)	500 kg	1100 lb

\* CUSTOM SIZES ARE AVAILABLE ON REQUEST

### EQUIPMENT RANGES

ARM RANGE (MAX FROM THE CENTRE)	6765 mm	266.3 in
ARM RANGE (MIN FROM THE CENTRE)	1050 mm	41.3 in
FIRST JOINT	0 - 360°	0 - 360°
HOIST WITH WIRED PENDANT CONTROLLER	YES	YES

POWER REQUIRED	400v 3ph 50Hz	208v 3ph 60Hz
	3A+ Neutral	5A

CONNECTIONS REQUIRED (SUPPLIED BY CUSTOMER) -  
POWER

NB - VACUUM LIFTER SHOWN FOR ILLUSTRATION PURPOSES ONLY

FARNESE DO NOT SUPPLY BOLTS AND CHEMICAL SETS

Owing to the constant updating of our designs, descriptions and technical data shown in our drawings and folders are not binding. Possible alterations deemed by the makers as convenient will be effected at any time without previous notice.

5 Heald Road, Ingleburn NSW 2565 Australia  
ABN: 47 057 462 629 • ACN: 057 462 629  
Phone: 1300 075 678 • [www.farnese.com.au](http://www.farnese.com.au)

DESIGNED FOR FUNCTION, BUILT TO LAST.

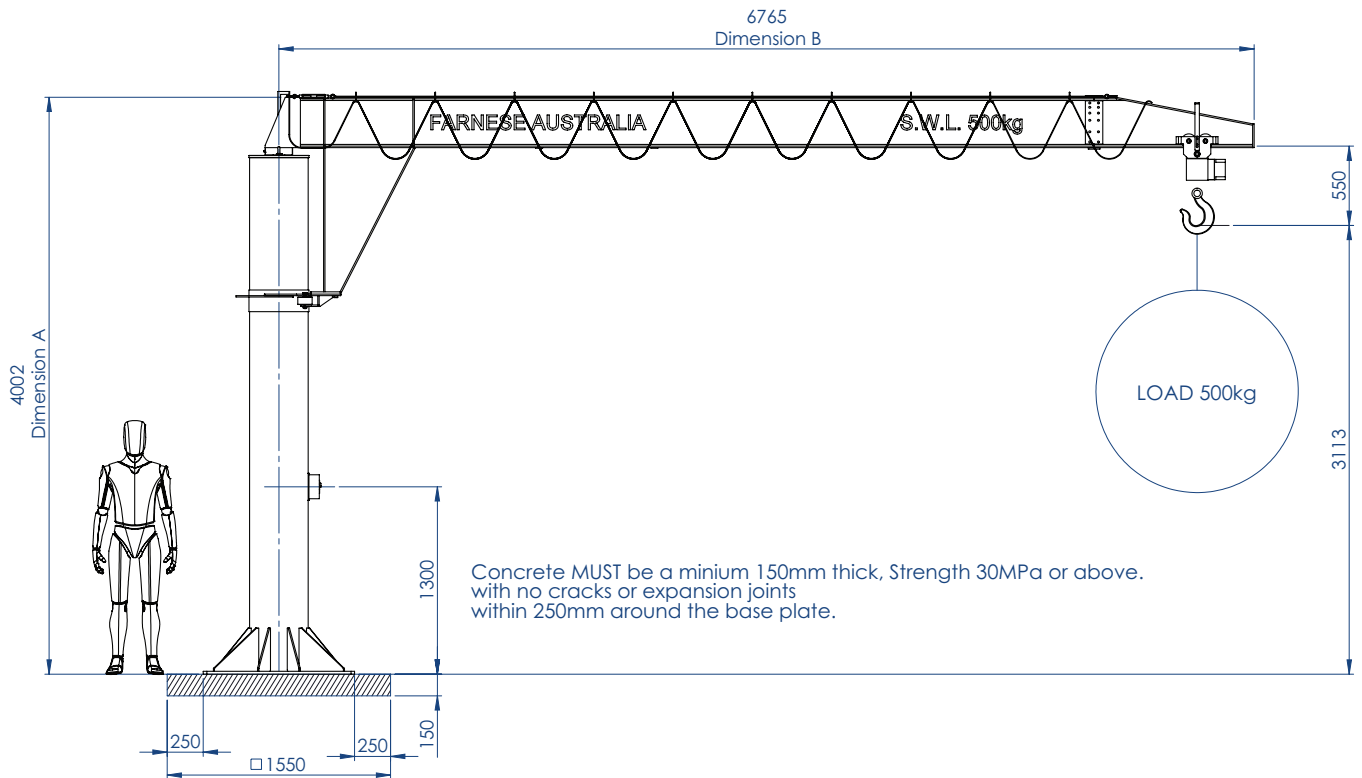

## We Know That Support Is Important To You

Buying a new machine is a big commitment for anyone, and continued support throughout the life of that machine is vital.

Being an Australian company, Farnese carry a vast array of parts here in Australia to ensure that your machine always has the spares it needs. Enjoy peace of mind knowing that you'll be fully supported by Farnese and we'll always have you covered.

Farnese customers don't need to experience unnecessary machinery downtime waiting for remote assistance from other countries, as all the support and remote assistance is provided locally in Australia from our own qualified Technicians in Australian time.

With more Service Technicians in Australia than any of our competitors, our mission here at Farnese is to give you the best support in the industry. As we grow, we continue to recruit more and more qualified technicians, to further strengthen our position in the Stone Industry.